



FALCON PREDATOR EVO4 + 2
Vehicle Security System with Remote Starter & LCD Pager
Installation Manual

Table of Contents:

A) Introduction	2
A-1) Features	2
A-2) Key Function Table	2
B) Optional Programming Features	3
C-1) Programming Option Table	3
B-2) Explanation of Programming Options	4
C) Remote Transmitter Code Learning	7
D) Installation Notes	7
D-1) Ignition 2 Connection	7
D-2) Installation without Remote Starter Features	7
E) Suggested Location of Installing the Antenna	8
F) Wiring Diagram	9
G) Wiring Note #1	10
H) Wiring Note #2	11

HELPLINE: 0906 700 10 20

(All calls charged at 50p/min)

Falcon Security Ltd. Unit 9 Tanning Court, Warrington, Cheshire, WA1 2HF, UK
Internet: <http://www.falcon-security.com> Email: support@falcon-security.com

A) Introduction

The Falcon Predator EVO4+2 is a unique Vehicle Security System with Remote Engine Starter System and is designed to provide the highest level of security and convenience.

Thanks to the built in two-way interactive communications system the small palm size LCD remote transmitter will instantly alert you audibly and if the alarm is triggered.

The Falcon Predator EVO4+2 has many programmable functions so please read this manual carefully before installing the Falcon Predator EVO4+2 system.

A-1) Features

- 1 x Two Way LCD Remote Transmitter and 1 x one way 2nd remote
 - Code Hopping and Code Learning Remote System
 - Up to 4 remote transmitters Programmable
 - Remote Engine Start with system armed/disarmed
 - Timer Engine Start
 - Turbo Timer
 - Remote Arm/Disarm
 - Mute Arm/Disarm
 - Immobiliser
 - Remote Boot Release
 - Passive or Active Lock Programmable
 - Auto Re-arm
 - Ignition Lock/Unlock
 - Car Finder
 - LCD Remote: Vibrate or Audible Alert
 - LCD Back Light Display
- LCD Remote: low battery warning
 - Audible Intrusion Zone Identification
 - Defective Zone Alert and Bypass
 - Keyless Entry While Ignition is on
 - Remote Panic Alarm
 - Anti-Hijacking
 - Emergency System Override
 - Remote Valet Mode
 - Passive Arming
 - Siren programmable for 30 or 60 seconds
 - Built in Central Locking Control
 - Built in Total Closure Control
 - Central Lock Active Time selectable 0.5 or 3.5 seconds
 - Plug-In Dual Stage Shock Sensor
 - Shock Sensor Bypass
 - Vehicle Status Report
 - Interior Light Delay Time programmable

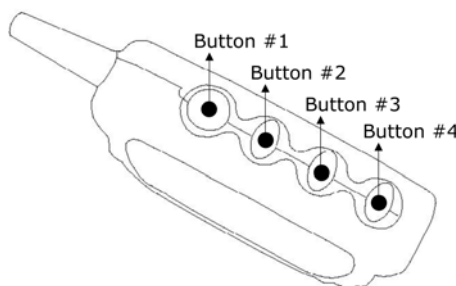

A-2) Key Function Table

Button	Armed	Disarmed	Ignition On
Button 1 once	Arm	Arm	
Button 2 once	Disarm	Disarm	
Button 1 for 3 secs	Panic	Panic	Panic
Buttons 1+3 for 1 sec	Channel 3	Channel 3	Channel 3
Button 3 once	Car Finder	Car Finder	Anti-Hijacking
Button 3 for 2 secs	Boot Release	Boot Release	RPM Learning
Button 4 for 3 secs	Remote Start On/Off	Remote Start On/Off	
Button 4 once	LCD Remote Back Light	LCD Remote Back Light	LCD Remote Back Light
Buttons 1+2 once	Mute Disarm	Mute Arm	Valet Mode
Buttons 1+4 for 1 sec	Timer Start On/Off	Timer Start On/Off	
Buttons 2+3 once	Status Report	Status Report	Status Report
Buttons 2+4 once		LCD Remote Power Saving	LCD Remote Power Saving
Buttons 3+4 once	Vibrate Alert On/Off	Vibrate Alert On/Off	Vibrate Alert On/Off

B) Optional Programming Features

The Predator EVO4+ has additional features for different types of vehicles.

Read the below programming functions carefully to have the right options programmed for your vehicle and your needs.

a> Under the system disarm mode, keep the door open, and switch the ignition on-off, on-off, on-off and then back to On.

b> Siren will chirp for 2 seconds to confirm entering the programming option mode.

c> To choose the function #1 – 23: Within 20 seconds after taking step b Press button 1 the same number of times as the function # you wish to program. Each time you press button 1, a single short chirp will follow. For example, if you want to choose #11 Start Mode Select, press button 1 eleven times.

Pressing Button 4 for 3 seconds will the programming options will be reset to factory default, the siren will chirp for 2 seconds to confirm and the system will leave programming mode.

d> To confirm the selected mode, Press button 2. Siren will chirp as many times as you pressed button 1 in step C to confirm the function you chose. For example, if you press button 1 eleven times in step C, 11 single short chirps will follow.

e> Now you can program the features and settings by pressing buttons 1, 2 or 3.

When you press button 1, a single chirp will sound, for Button 2 two chirps and button 3 three chirps to indicate the selected setting has been programmed.

The system will leave the programming mode if there is no action made within 20 seconds your previous action or the ignition is turned off. The siren will sound for 2 seconds to confirm the system has left programming mode.

C-1) Programming Option Table

No.	Function	BTN (1) Chirp Once	BTN (2) 2 Chirps	BTN (3) 3 Chirps
01	Chirp Confirmation On/Off	On	Off	
02	Shock Sensor Bypass	Disabled	First	Both
03	Passive Arming	Disabled	Enabled	
04	Passive Locking	Disabled	Enabled	
05	Ignition Locking	Disabled	Enabled	Lock Only
06	Door Lock Time	1 Pulse	2 Pulses	4 Sec.
07	Siren/Horn	Siren	Horn	
08	Alarm Condition/Cycle Duration	30 Secs	60 Secs	
09	Interior Light Delay	Disables	15 Secs	
10	Auto Rearm	Disabled	Enabled	
11	Anti-Hijacking Delay	15 Secs	60 Secs	
12	Anti-Hijacking by Remote Control	Disabled	Enabled	
13	Anti-Hijacking by Door Opening	Disabled	Enabled	
14	Turbo Timer	Disabled	120 Secs	180 Secs
15	Car Type	Automatic	Manual	
16	Remote Start Conditions	Arm	Normal	
17	Door Lock/Unlock with Remote Start	Disabled	Enabled	
18	Remote Start Mode	Alternator	TACH	
19	Crank Time	600ms	800ms	1000ms
20	Engine Running Time	10 Min	20 Min	
21	Timer Start	3 Hours	6 Hours	12 Hours
22	Alternator Voltage	4.5V	9.0V	
23	Channel 3 Output	Disable	Enable	

*Note: The factory defaults are pre-programmed as per the first column (grey box).

B-2) Explanation of Programming Options

01) Chirp confirmation on/off: Factory default = On

The siren will chirp once to enter armed mode and twice to enter disarmed mode when programmed as on. The siren will not chirp if programmed as off.

02) Shock Sensor Bypass: Factory default = Disabled

When programmed as Disabled: The shock sensor will work normally

When programmed as First: The 1st stage shock sensor will be bypass after 3 continual triggers

When programmed as Both: Both stages of the shock sensor will be bypassed after 3 continual triggers.

03) Passive Arming: Factory default = Disable

When programmed as Disabled: The feature will not be activated

When programmed as Enabled: The LED will flash rapidly and system will enter the armed mode automatically after 30 seconds of turning the ignition off and closing the last opened door, the bonnet and boot. The siren will chirp and parking lights flash once to confirm and the immobiliser turns on.

04) Passive Locking: Factory default = Disabled

When programmed as Disabled: The doors will not be locked when the passive arming feature is activated.

When programmed as Enabled: The doors will be locked when the passive arming feature is activated.

05) Ignition lock: Factory default = Disabled

When programmed as Disabled: The doors will not be locked when turning the ignition on and will not be unlocked when the ignition is off

When programmed as Enabled: The doors will be automatically locked 15 seconds after the ignition is turned on and the doors will be unlocked immediately upon the ignition being turned off

When programmed as Lock Only: The doors will be locked 15 seconds after turning the ignition on but will not be unlocked after turning the ignition off.

06) Door lock time: Factory default = 1 Pulse

When programmed as 1 Pulse: The system will send one 1 second pulse when locking or unlocking the doors.

When programmed as 2 Pulse: The system will send one 1 second pulse when locking the doors and two 1 second pulses when unlocking the doors.

When programmed as 4 sec.: The system will send one 4 second pulse when locking or unlocking the door.

07) Siren/Horn: Factory default = Siren

When programmed as Siren: The system will send a constant output

When programmed as Horn: The system will send an intermittent output with a 0.5 second interval between each output. An extra relay should be added if Horn is selected.

08) Alarm condition cycle duration: Factory default = 30 seconds.

To program the alarm time as 30 or 60 seconds.

09) Interior light delay: Factory default = Disabled

If the vehicle has a delay on turning off the interior light when closing the door, set the Interior Light Delay to 15 or 40 Secs.

When programmed as Disabled: The siren will chirp, hazard lights will flash 3 times and LED will show 3 flashes if the door, boot or bonnet is not closed properly. When the system enters armed mode the violated zone will be bypassed but all other areas will remain protected.

When programmed as 15 or 40 seconds: If the door, boot or bonnet is not closed properly the siren will chirp, hazard lights will flash 3 times and the LED will show 3 flashes. 15 or 40 seconds later the system enters armed mode and the violated zones will be bypassed but all other areas will remain protected.

10) Auto rearm: Factory default = Disabled

If Auto Rearm is Enabled, the system will be armed again 30 seconds after the system is disarmed if a door is not opened. Opening a door after disarming the system will disable Auto rearm function.

11) Anti-Hijacking Delay: Factory default = 15 Sec.

The system will enter anti-hijacking mode 15 or 60 seconds after the anti-hijacking is activated by pressing the remote control or opening the door while the ignition is on.

12) Anti-hijacking by remote control: Factory default = Disabled

When programmed as Enabled Anti-Hijacking mode can be started by pressing button 3 on the remote control

13) Anti-hijacking by door opening: Factory default = Disabled

When programmed as Enabled: The anti-hijacking mode will be activated by opening a door with the ignition on.

14) Turbo timer: Factory default = Disabled

When programmed as 120 or 180 Secs: The ignition will keep on running for 120 or 180 seconds after turning the ignition key off and closing the door.

Operation is as follows:

- With the ignition key still in on position
- Pull up the handbrake
- Turn the ignition key to the off position
- The Ignition and ACC circuits will stay on
- The system will then start the 120 or 180 seconds countdown
- Open and close the door
- The Ignition and ACC circuits will stay on
- After 120 or 180 seconds, the ignition and ACC circuits will be turned off automatically.
- Pressing button 1 during the 120 or 180 seconds will arm the system (Press buttons 1+2 for Mute Arm)

* The turbo time will be functional only when the engine has been running for at least 5 minutes

15) Car type: Factory default = Automatic

Select Automatic for vehicles with automatic transmission or select manual for vehicles with a manual transmission.

16) Remote start conditions: Factory default = Arm

When programmed as Arm: The remote start feature will be functional only when the system is armed.

When programmed as Normal: The remote start feature will be functional when the system is armed or disarmed mode.

17) Lock/Unlock with remote start: Factory default: Disabled

When programmed as Disabled: The doors will not lock or unlock before and after the remote engine starter operates.

When programmed as Enabled: If the system is armed: The doors lock once before and after remote starting the engine.

If the system is disarmed the door unlocks before and after remote starting the engine.

18) Remote start mode: Factory default = Alternator
To program the Remote Start Mode as Alternator or Tach.

RPM (TACH) Learning:

- Perform the Tach Learning before using the remote start for the first time
- Make sure the Tach wire(C4-1 Green) of the alarm system is connected to the negative of the coil as shown in the wiring diagram

Before performing the RPM (Tach) learning turn off all electrical devices such as car stereo, FM Radio or air conditioner. By doing so, the system will learn lowest RPM, which will make it smoother and easier when using the remote starter.

Take the following steps to perform the RPM learning:

a> Shift the gear to the neutral position and pull up the hand brake.

b> Switch the ignition on and start the engine.

c> Wait until the RPM is running stably (normally vehicle's stable RPM is 900-1,000.)

d> Press button 2 for 2 seconds. The hazard lights will flash for 2 seconds and then flash twice to confirm that RPM is learned.

Important:

* Please make sure to set Start Mode Select as TACH (please refer to # 18 Remote Start Mode of Programming Option Table).

* The Tach wire (Green) of the alarm system should be connected to the negative of the coil.

19) Crank time: Factory default = 600ms

Normally, older vehicles and diesel vehicles need a longer crank time to start the engine. However, if the engine doesn't start smoothly, please set the crank time longer.

*For diesel vehicles please try to program 1000ms in order make the remote engine start work smoothly.

20) Engine running time: Factory default = 10 minutes

Depending on the programmed engine running time the engine will run for 10 or 20 minutes and then shut down automatically.

21) Timer start: Factory default = 3 Hours

With the system armed or disarmed the Timer Start feature can be turned on or off as follows:

A) Turn on Timer Start Mode:

- Press buttons 1+4 once, the siren will chirp and hazard lights will flash once to confirm the feature has been turned on for 24 hours.

- The engine will be started every 3, 6 or 12 hours depending on the selection of option feature #21

B) To turn off Timer Start Mode Press buttons 1+4 once, the siren will chirp and hazard lights will flash twice to confirm the feature has been cancelled.

Timer Start mode will be cancelled in the situations below:

* When remotes engine start is used.

* If the ignition has been turned on with the system disarmed

* The doors are opened with the system armed

22) Alternator voltage: Factory default = 4.5V

This setting should be left set on the default setting of 4.5V unless advised otherwise by the technical department of supplier.

23) Channel 3 output: Factory default = Disabled

The channel 3 output is often applied for total closure/comfort closure and the operation is as follows:

When programmed as Enabled: The windows will be closed automatically when pressing button 1 or 1+2 to arm the system. With the feature enabled, the CH3 output will be unable to be operated by remote control.

When programmed as Disabled: The channel 3 output will be activated as long as pressing and holding buttons 1+3 for 1 second.

C) Remote Transmitter Code Learning

The included remotes control are programmed to the system before they leave the factory. Follow the below procedure to program a new remote control:

a> Follow the below procedure to program a new remote control.

With the alarm disarmed, and the doors CLOSED, switch the ignition ON/OFF 3 times (within 1 second of each other) and then back to the ON position.

The siren will sound for 2 seconds to indicate the alarm is in code learning mode.

b> To program the new remote control press button (1) within 10 seconds.

The siren will chirp and the hazard lights flash twice to confirm that the code has been learned. Follow the same procedure for second, third and fourth remote transmitter.

c> If the ignition is turned OFF or button (1) is not pressed within 10 seconds, the system will quit the code-learning mode. If this happens you must start again from the first step.

d> Up to 4 remote control transmitters can be programmed to the system.

D) Installation Notes

D-1) Ignition 2 Connection

If a vehicle has ignition 2 (ACC 2), the yellow/black wire (C4-2) must be connected to Ignition 2 (ACC 2) via a 30A relay as shown below.

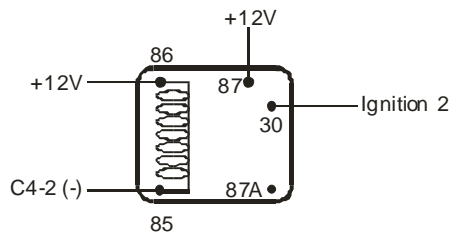

Important: This wire must be connected to Ignition 2 (ACC 2) in the vehicle. Or it will affect performance of remote engine start.

D-2) Installation without Remote Starter Features

If the remote starter and turbo timer features are not required, the following wires do not need to be connected:

- C1-2 Yellow/Green To Ignition Start
- C1-3 Blue/White To Ignition Acc
- C3-5 Black/Red To handbrake light
- C4-1 Green To RPM
- C4-2 Yellow/Black To ignition 2
- C4-3 Red/Black To alternator

E) Suggested Location of Installing the Antenna

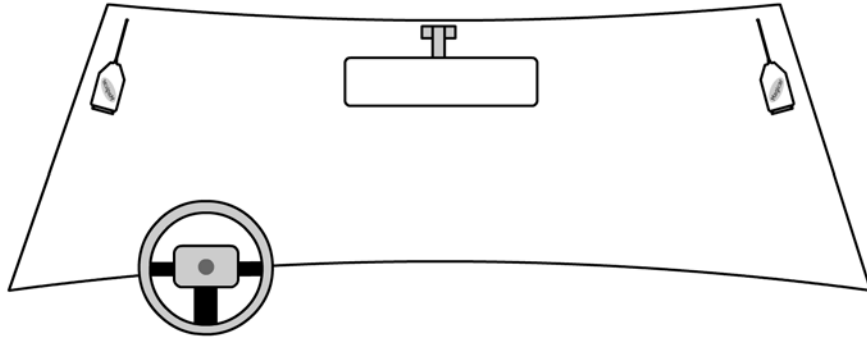

- * Install the antenna at the right or left upper of the windshield
- * Keep the antenna at least 5cm away from the car frame
- * Don't power on the main unit if the antenna is not connected
- * Keep the antenna at least 5cm apart from solar control window film

Falcon Predator EVO4+ Car Alarm With Remote Starter & LCD Pager Wiring Diagram

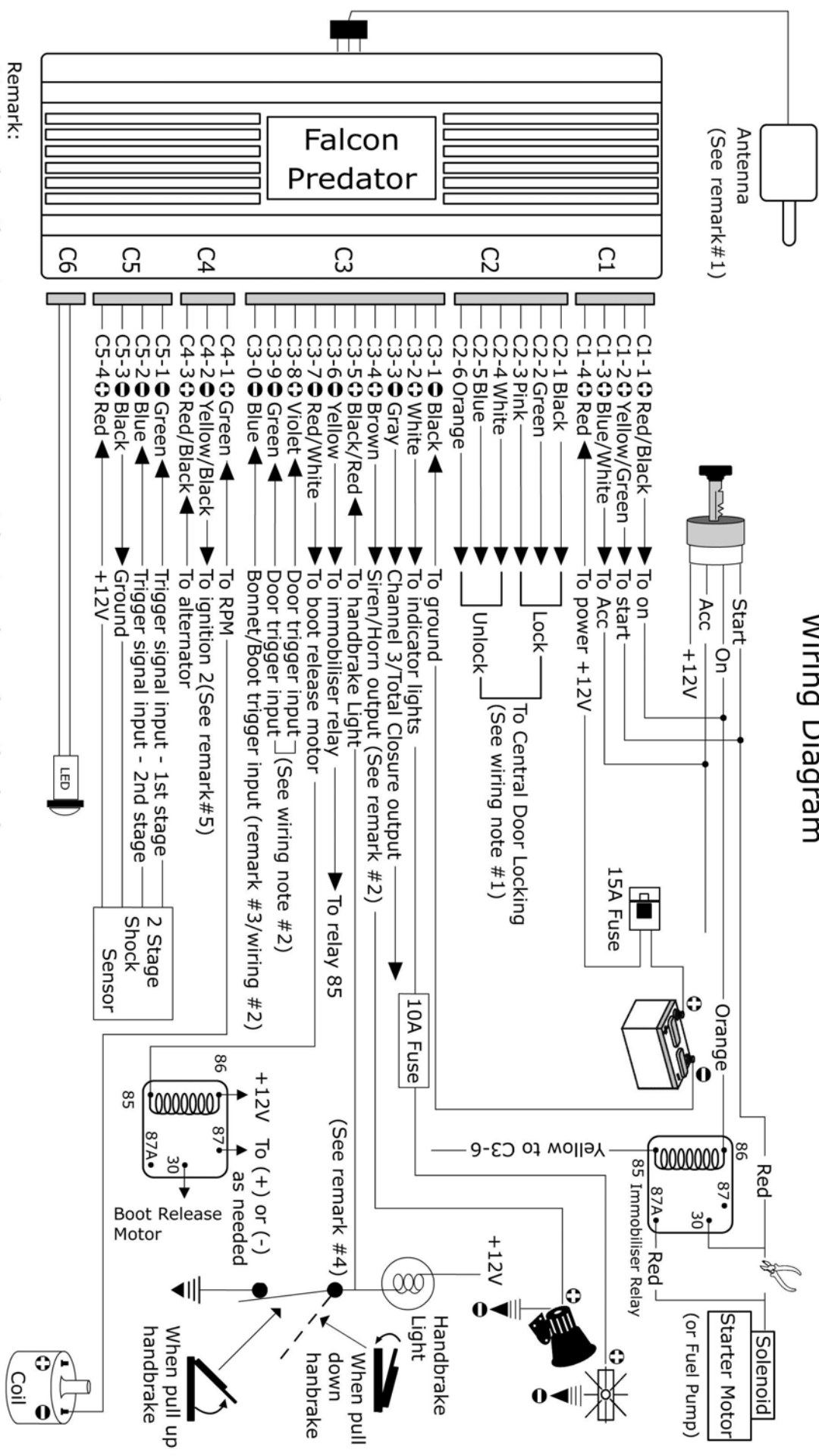

F) Wiring Diagram

- Remark:
- #1: Please keep the antenna away from any metal parts and away from the shock sensor.
 - #2: If connecting to vehicles horn, please add a relay.
 - #3: Connect C3-0 to bootlight and bonnet pin-switch in parallel.
 - #4: C3-5 must be connected to ground otherwise the remote start will not work.
 - #5: If the vehicle has ignition 2(ACC 2), this wire must be connected to ignition 2(ACC 2) of the vehicle **via a relay** - see page 6 of manual.

G) Wiring Note #1

Predator EVO4 Wiring Note #1

Central Locking Wiring Diagram

Diagram #A

Original built-in central door locking

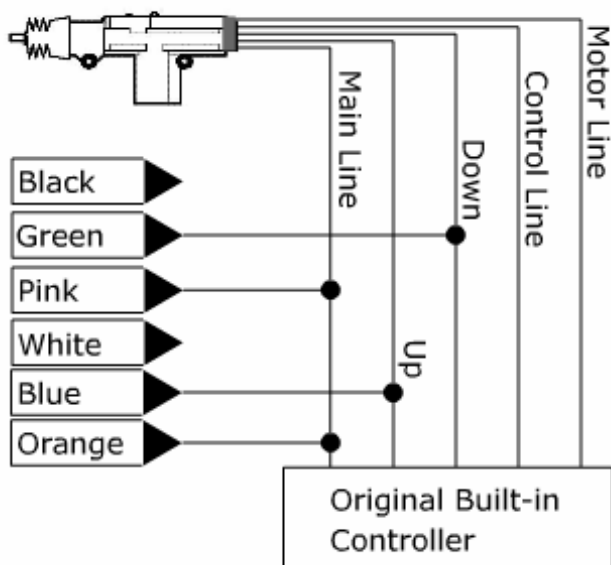

Diagram #B

Original built-in central door locking & electric power lock switch where installed
For example: CHRYSLER

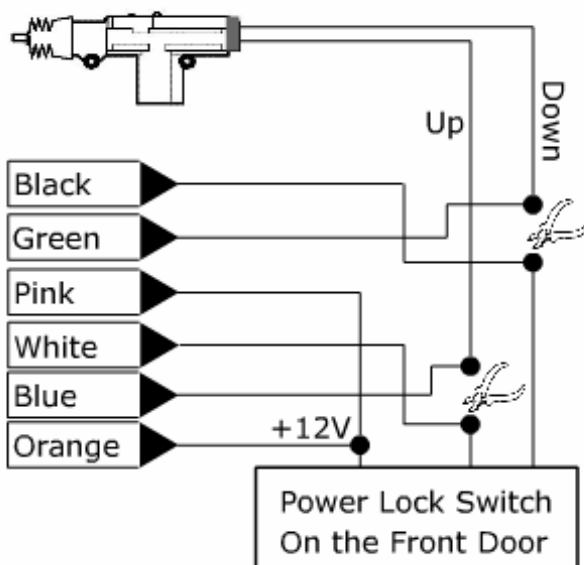

Diagram #C

Original built-in central locking & where only a switch existed in the drivers door.
A motor is required

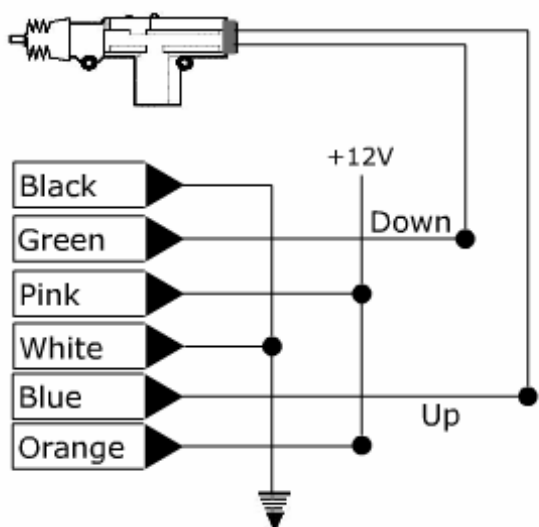
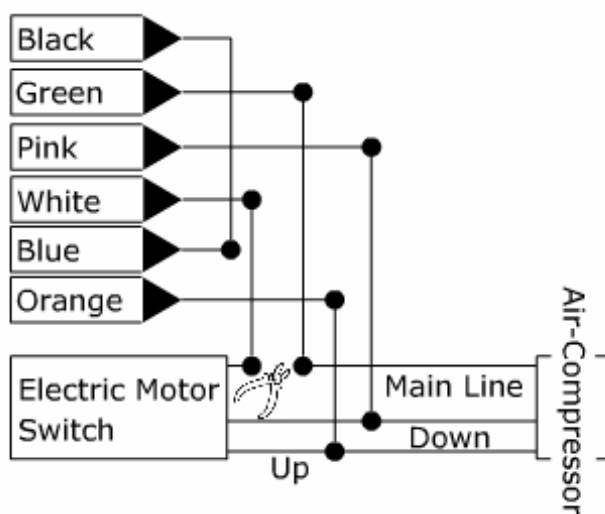

Diagram #D

Original built-in central locking using a compressor to control the switch.
For example: BENZ, AUDI
(Note: Active time 3.5 sec.)



H) Wiring Note #2

Predator EVO4 Wiring Note #2

Connect the C3-9 Green Door-trigger wire to the interior light or C3-0 Blue Bonnet/Boot trigger wire to the boot light as follows:

Negative Trigger: When the vehicle's Interior Light or Boot Light is Negative Trigger

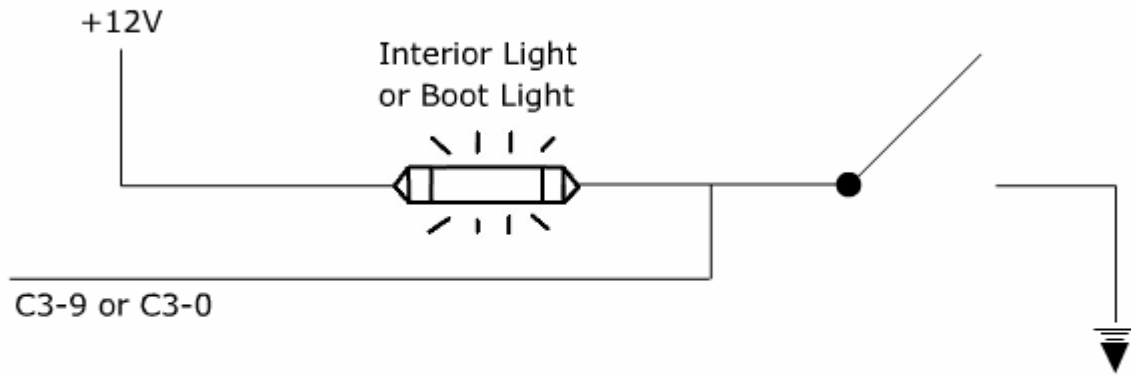

Positive Trigger: When the vehicle's Interior Light or Boot Light is Positive Trigger

